

## *HYPERON Ultra / HYPERON clincher 9s / 10s*

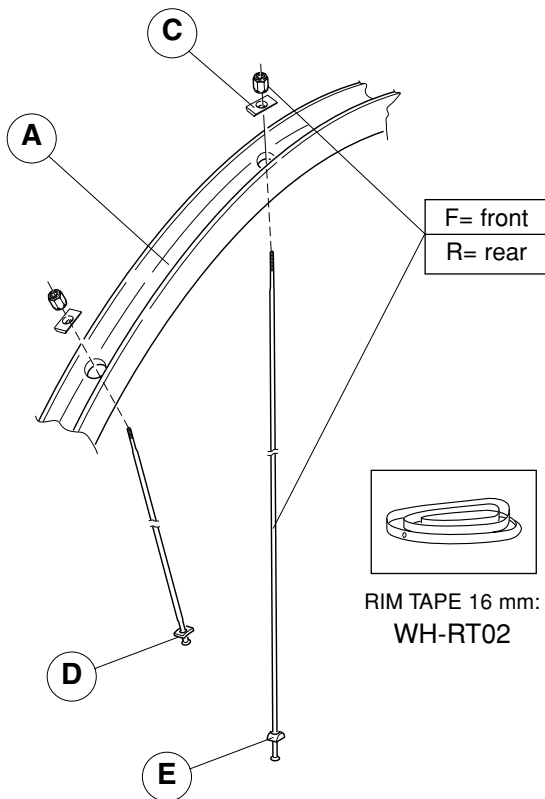

COMPLETE WHEELS	A	Compl. KIT	MINI-KIT
<b>FRONT</b>			
WH4-HYCFU clincher 28"	WH-003HYU	KIT-03HYU (24F+24C)	<b>HYPERON ULTRA KIT-200HYU</b> (2F+2R right +2R left+6C+2E)
WH4-HYCF clincher 28"	WH-003HY	KIT-03HY (24F+24C+24D)	
<b>REAR</b>			
WH4-HYCRU clincher 28"	WH-004HYU	KIT-04HYU (13R right+13R left+26C+13E)	<b>HYPERON KIT-200HY</b> (2F+2R right +2R left+6C+4D+2E)
WH4-HYCR WH4-HYCRX clincher 28"	WH-004HY	KIT-04HY (13R right+13R left+26C+13D+13E)	

COMPLETE WHEELS	F	R right	R left
WH4-HYCFU clincher 28"	L. 292 mm WH-005HYC (10 pcs.)		
WH4-HYCF clincher 28"	L. 292 mm WH-005HYC (10 pcs.)		
WH4-HYCRU clincher 28"		L. 292 mm WH-006HYC (10 pcs.)	L. 291 mm WH-007HYC (10 pcs.)
WH4-HYCR WH4-HYCRX clincher 28"		L. 292 mm WH-006HYC (10 pcs.)	L. 291 mm WH-008HYC (10 pcs.)

**HYPERON**  
**tubular**  
**9s / 10s**

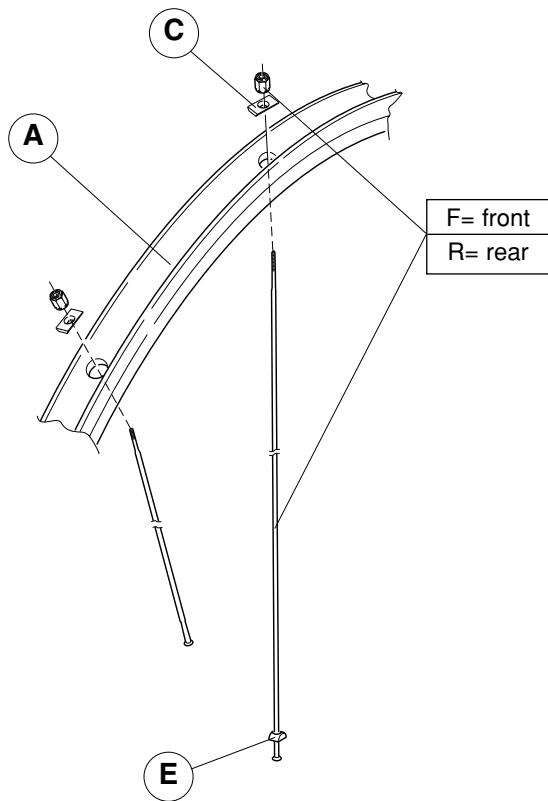

COMPLETE WHEELS	A	Compl. KIT	MINI-KIT
<b>FRONT</b>			<b>KIT-100HY</b> (2F+2R right +2R left+6C+2E)
<b>WH02-HYTF</b> tubular 28"	<b>WH-001HY</b>	<b>KIT-01HY</b> (24F+24C)	
<b>REAR</b>			
<b>WH02-HYTR</b> <b>WH02-HYTRX</b> tubular 28"	<b>WH-002HY</b>	<b>KIT-02HY</b> (13R right+13R left+26C+13E)	

COMPLETE WHEELS	F	R right	R left
<b>WH02-HYTF</b> tubular 28"	L. 294,5 mm WH-005HYT (10 pcs.)		
<b>WH02-HYTR</b> <b>WH02-HYTRX</b> tubular 28"		L. 295 mm WH-006HYT (10 pcs.)	L. 294,5 mm WH-007HYT (10 pcs.)

## NEUTRON 9s / 10s

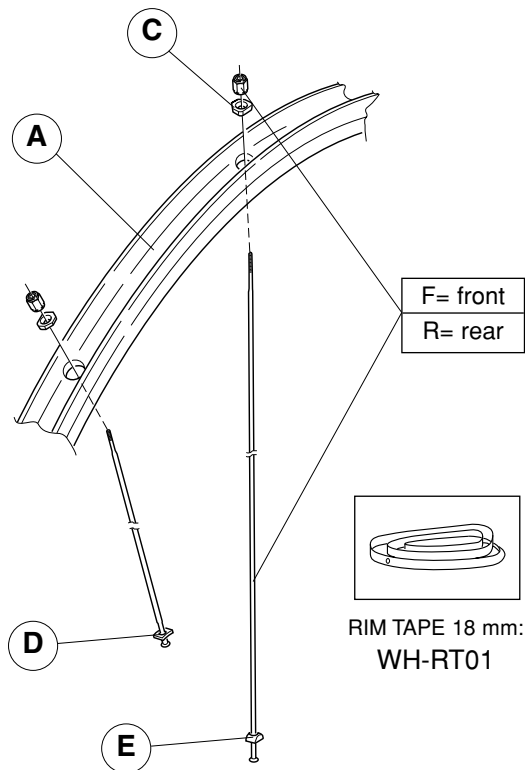

COMPLETE WHEELS	A	Compl. KIT	MINI-KIT
<b>FRONT</b>			
<b>WH02-NETF</b> tubular 28"	<b>WH-001NE</b>	<b>KIT-01NE</b> (24F+24C+24D)	<u>tubular</u> <b>KIT-100NE</b> (2F+2R right +2R left+6C+4D+2E)
<b>WH4-NECF</b> clinchner 28"	<b>WH-103NE</b>	<b>KIT-03NE</b> (24F+24C+24D)	
<b>REAR</b>			
<b>WH02-NETR</b> <b>WH02-NETRX</b> tubular 28"	<b>WH-002NE</b>	<b>KIT-02NE</b> (13R right+13R left+26C+13D+13E)	<u>clinchner</u> <b>KIT-200NE</b> (2F+2R right +2R left+6C+4D+2E)
<b>WH4-NECR</b> <b>WH4-NECRX</b> clinchner 28"	<b>WH-104NE</b>	<b>KIT-04NE</b> (13R right+13R left+26C+13D+13E)	
COMPLETE WHEELS	F	R right	R left
<b>WH02-NETF</b> tubular 28"	L. 296,5 mm WH-005NET (10 pcs.)		
<b>WH4-NECF</b> clinchner 28"	L. 294,25 mm WH-005NEC (10 pcs.)		
<b>WH02-NETR</b> <b>WH02-NETRX</b> tubular 28"		L. 299,5 mm WH-006NET (10 pcs.)	L. 296,5 mm WH-007NET (10 pcs.)
<b>WH4-NECR</b> <b>WH4-NECRX</b> clinchner 28"		L. 296,5 mm WH-006NEC (10 pcs.)	L. 294,75 mm WH-007NEC (10 pcs.)

# PROTON 9s / 10s

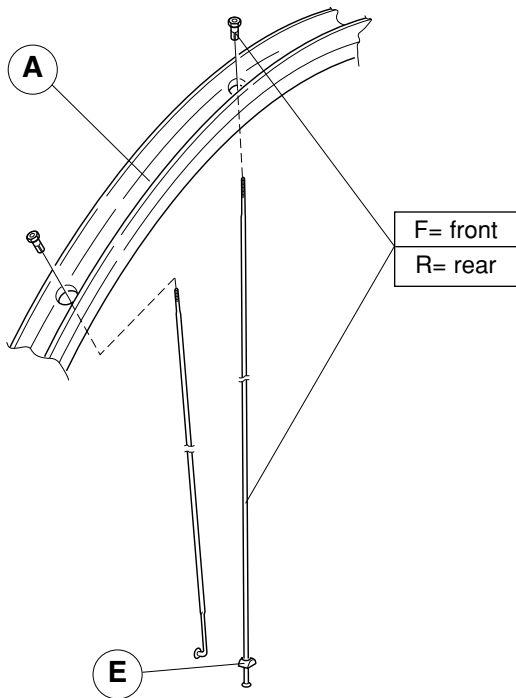

COMPLETE WHEELS	A	Compl. KIT	MINI-KIT
<b>FRONT</b>			
<b>WH4-PRCF</b> clincher 28"	<b>WH-201PR</b>	<b>KIT-03PR</b> (24F)	<b>KIT-400PR</b> (2F+2R right +2R left+2E)
<b>REAR</b>			
<b>WH4-PRCR</b> <b>WH4-PRCRX</b> clincher 28"	<b>WH-202PR</b>	<b>KIT-04PR</b> (13R right+13R left+13E)	

COMPLETE WHEELS	F	R right	R left
<b>WH4-PRCF</b> clincher 28"	L. 283 mm WH-005PRC (10 pcs.)		
<b>WH4-PRCR</b> <b>WH4-PRCRX</b> clincher 28"		L. 292 mm WH-006PRC (10 pcs.)	L. 283 mm WH-005PRC (10 pcs.)

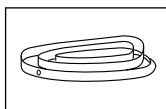

RIM TAPE 18 mm:  
WH-RT01

## EURUS 9s / 10s

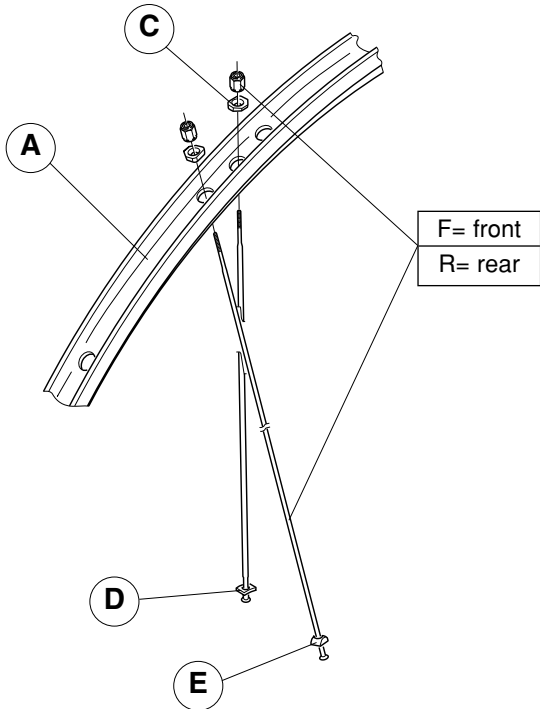

COMPLETE WHEELS	A	Compl. KIT	MINI-KIT
<b>FRONT</b>			
WH02-EUCF clincher 28"	WH-003EU	KIT-03EU (18F+18C+18D)	<b>KIT-200EU</b> (2F+2R right +2R left+6C+4D+2E)
<b>REAR</b>			
WH02-EUCR WH02-EUCRX clincher 28"	WH-004EU	KIT-04EU (15R right+8R left+23C+8D+15E)	

COMPLETE WHEELS	F	R right	R left
WH02-EUCF clincher 28"	L. 285 mm WH-005EUC (10 pcs.)		
WH02-EUCR WH02-EUCRX clincher 28"		L. 288 mm WH-006EUC (10 pcs.)	L. 285 mm WH-007EUC (10 pcs.)

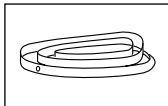

RIM TAPE 18 mm:  
WH-RT01

# ZONDA 9s / 10s

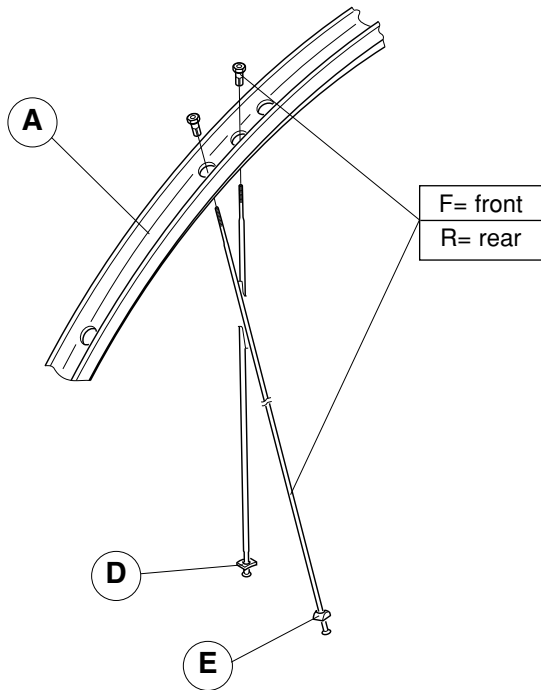

COMPLETE WHEELS	A	Compl. KIT	MINI-KIT
<b>FRONT</b>			
<b>WH4-ZOCF</b> clincher 28"	<b>WH-103ZO</b>	<b>KIT-13ZO</b> (18F+18D)	<b>KIT-300ZO</b> (2F+2R right +2R left+2E+4D)
<b>REAR</b>			
<b>WH4-ZOCR</b> <b>WH4-ZOCRX</b> clincher 28"	<b>WH-104ZO</b>	<b>KIT-14ZO</b> (15R right+8R left +8D+15E)	

COMPLETE WHEELS	F	R right	R left
<b>WH4-ZOCF</b> clincher 28"	L. 279 mm WH-005ZOC (10 pcs.)		
<b>WH4-ZOCR</b> <b>WH4-ZOCRX</b> clincher 28"		L. 282 mm WH-006ZOC (10 pcs.)	L. 279 mm WH-007ZOC (10 pcs.)

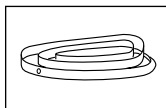

RIM TAPE 18 mm:  
WH-RT01

## SCIROCCO 9s / 10s

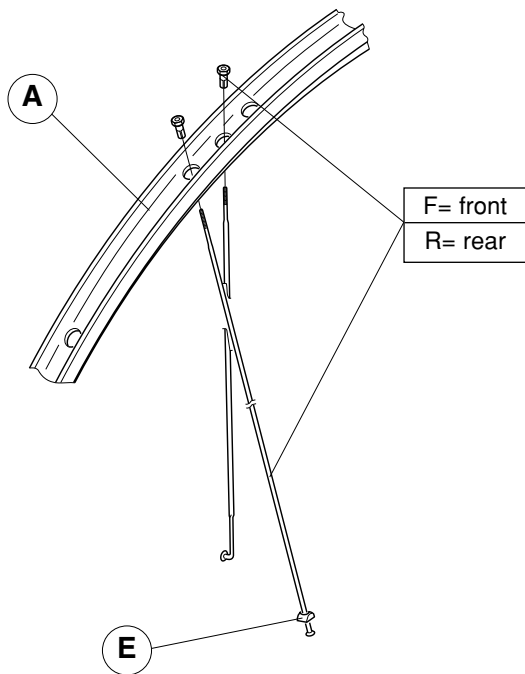

COMPLETE WHEELS	A	Compl. KIT	MINI-KIT
<b>FRONT</b>			
<b>WH4-SCCF</b> clincher 28"	<b>WH-003SC</b>	<b>KIT-23SC</b> (26F)	<b>KIT-500SC</b> (2F+2R right +2R left+2E)
<b>REAR</b>			
<b>WH4-SCCR</b> <b>WH4-SCCRX</b> clincher 28"	<b>WH-004SC</b>	<b>KIT-14SC</b> (17R right+9R left+17E)	

COMPLETE WHEELS	F	R right	R left
<b>WH4-SCCF</b> clincher 28"	L. 274 mm <b>WH-005SCC</b> (10 pcs.)		
<b>WH4-SCCR</b> <b>WH4-SCCRX</b> clincher 28"		L. 279 mm <b>WH-006SCC</b> (10 pcs.)	L. 272 mm <b>WH-007SCC</b> (10 pcs.)

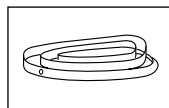

RIM TAPE 18 mm:  
**WH-RT01**

# VENTO 9s / 10s

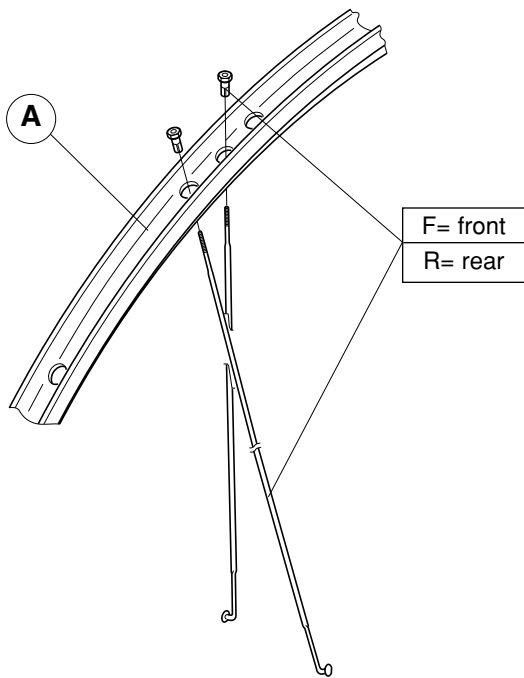

COMPLETE WHEELS	A	Compl. KIT	MINI-KIT
<b>FRONT</b>			
<b>WH4-VECF</b> clincher 28"	<b>WH-003VE</b>	<b>KIT-03VE</b> (26F)	<b>KIT-400VE</b> (2F+2R right +2R left)
<b>REAR</b>			
<b>WH4-VECR</b> <b>WH4-VECRX</b> clincher 28"	<b>WH-004VE</b>	<b>KIT-04VE</b> (19R right+10R left)	

COMPLETE WHEELS	F	R right	R left
<b>WH4-VECF</b> clincher 28"	L. 278 mm <b>WH-005VEC</b> (10 pcs.)		
<b>WH4-VECR</b> <b>WH4-VECRX</b> clincher 28"		L. 288 mm <b>WH-006VEC</b> (10 pcs.)	L. 278 mm <b>WH-007VEC</b> (10 pcs.)

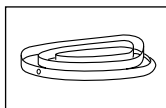

RIM TAPE 16 mm:  
**WH-RT02**



**BORA**  
**"full carbon"**  
**9s / 10s**

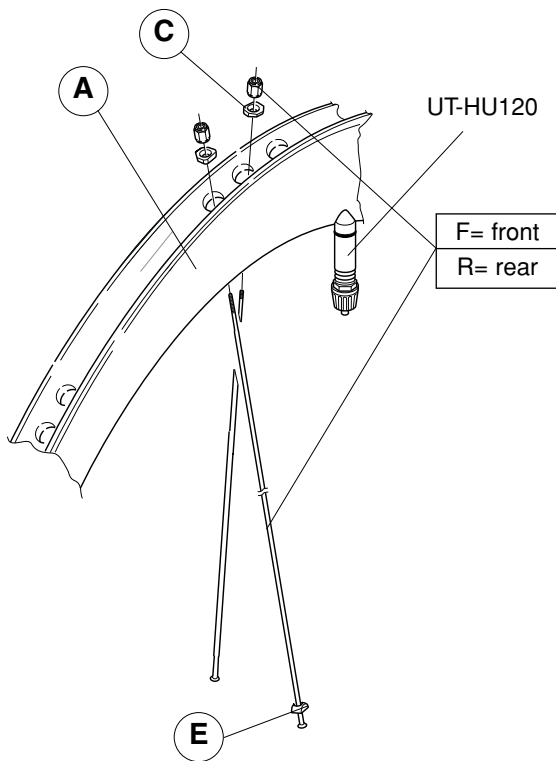

COMPLETE WHEELS	A	Compl. KIT	MINI-KIT
<b>FRONT</b>			
<b>WH03-BOTF</b> tubular 28"	<b>WH-401BO</b>	<b>KIT-21BO</b> (20F+20C)	<b>KIT-200BO</b> (2F+2R right +2R left+6C+2E)
<b>REAR</b>			
<b>WH03-BOTR</b> <b>WH03-BOTRX</b> tubular 28"	<b>WH-302BO</b>	<b>KIT-22BO</b> (15R right+8R left+23C+15E)	

COMPLETE WHEELS	F	R right	R left
<b>WH03-BOTF</b> tubular 28"	L. 264 mm <b>WH-005BOT</b> (10 pcs.)		
<b>WH03-BOTR</b> <b>WH03-BOTRX</b> tubular 28"		L. 268 mm <b>WH-006BOT</b> (10 pcs.)	L. 268 mm <b>WH-007BOT</b> (10 pcs.)

# PISTA

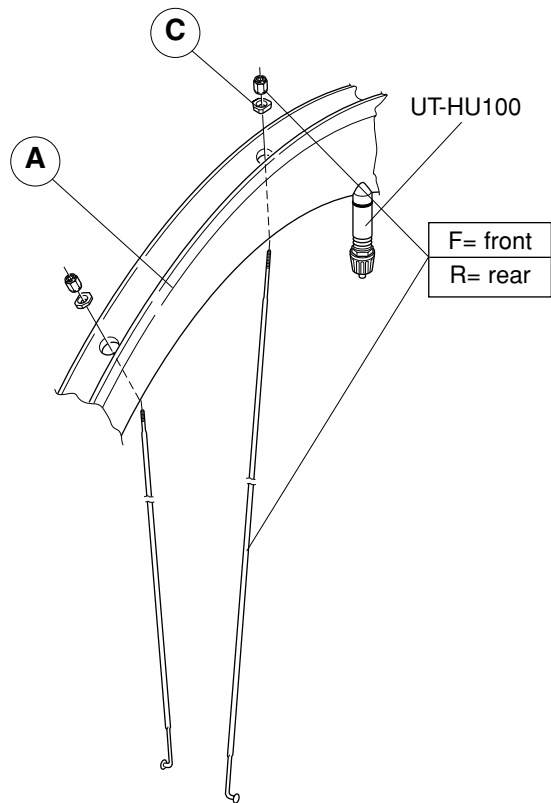

COMPLETE WHEELS	A	Compl. KIT	MINI-KIT	
<b>FRONT</b>				
<b>WH02-PTF</b> tubular 28"	<b>WH-001PI</b>	<b>KIT-01PI</b> (22F+22C)	<b>KIT-100PI</b> (3F+3R+6C)	
<b>REAR</b>				
<b>WH02-PTR</b> tubular 28"	<b>WH-002PI</b>	<b>KIT-02PI</b> (26R+26C)		

COMPLETE WHEELS	F	R
<b>WH02-PTF</b> tubular 28"	L. 278 mm WH-005PIT (10 pcs.)	
<b>WH02-PTR</b> tubular 28"		L. 287 mm WH-006PIT (10 pcs.)

**MOZZO ANTERIORE**  
***HYPERON tub. / HYPERON ULTRA clincher / BORA "full carbon" tub.***  
**FRONT HUB**

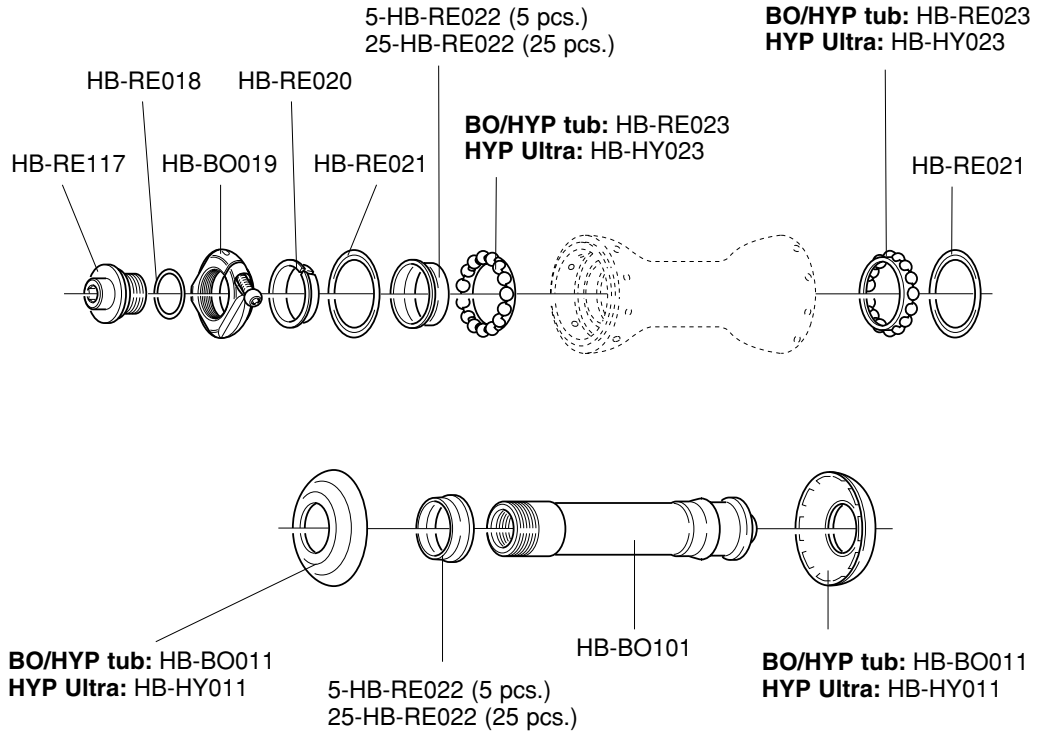

**MOZZO POSTERIORE 9s / 10s**  
***HYPERON tub. / HYPERON ULTRA clincher / BORA "full carbon" tub.***  
**9s / 10s REAR HUB**

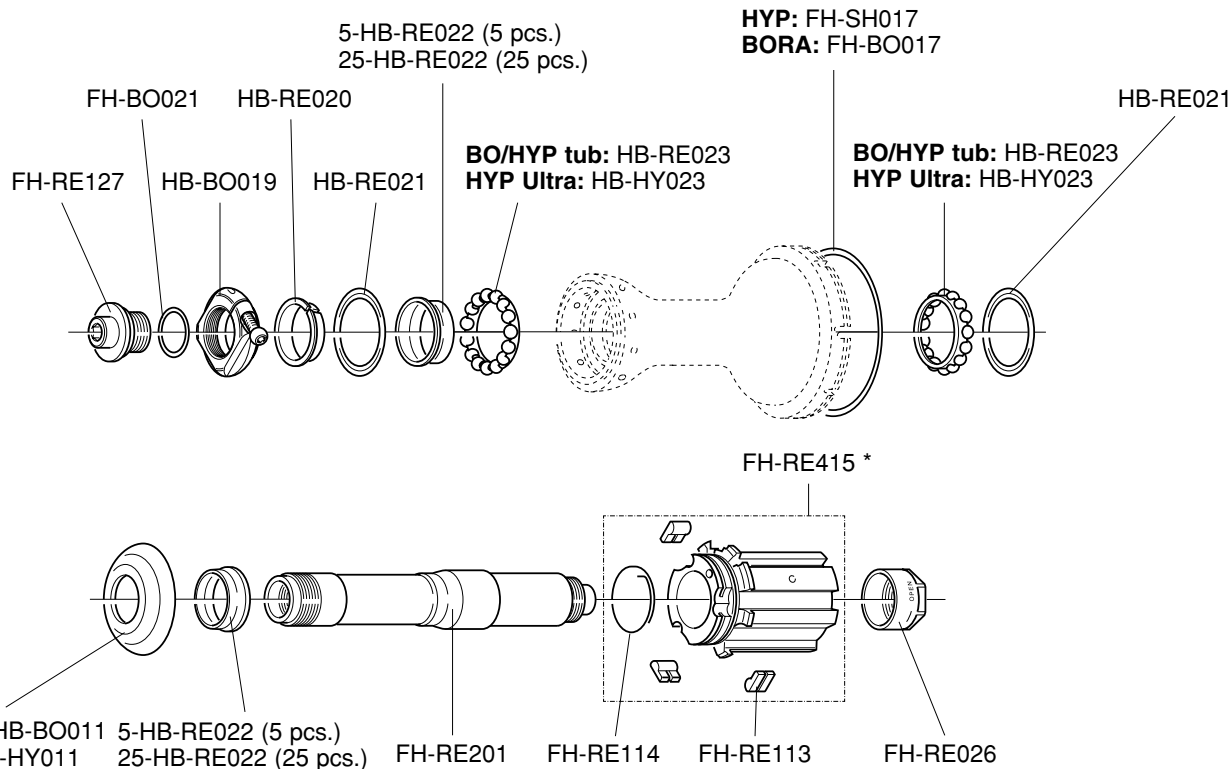

\* HG 8/9 type FW body / corpetto RL tipo HG 8/9: **WH-KX1** (RECORD type) **WH-KX2** (CHORUS type)

## MOZZO ANTERIORE *NEUTRON - EURUS - HYPERON clincher - ZONDA* FRONT HUB

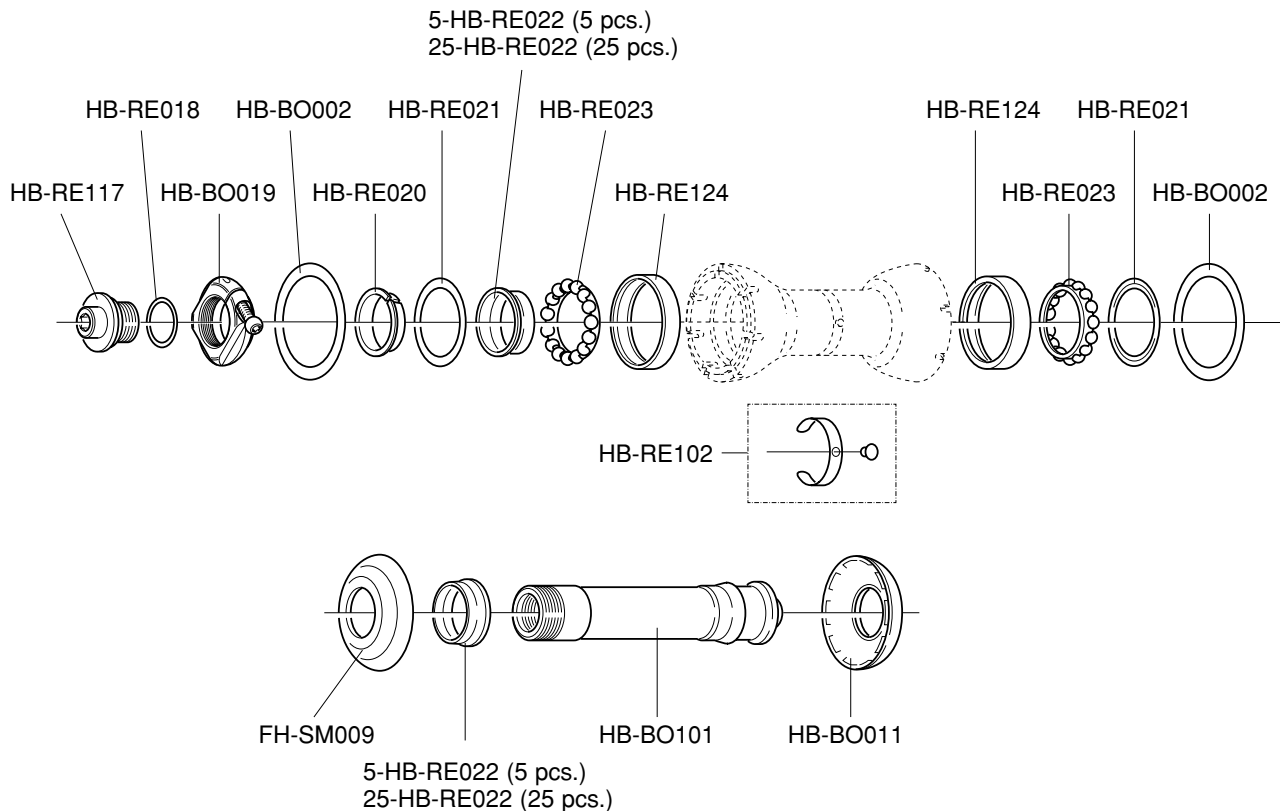

**MOZZO POSTERIORE 9s / 10s**  
**NEUTRON - EURUS - HYPERON clincher - ZONDA**  
**9s / 10s REAR HUB**

5-HB-RE022 (5 pcs.)  
 25-HB-RE022 (25 pcs.)

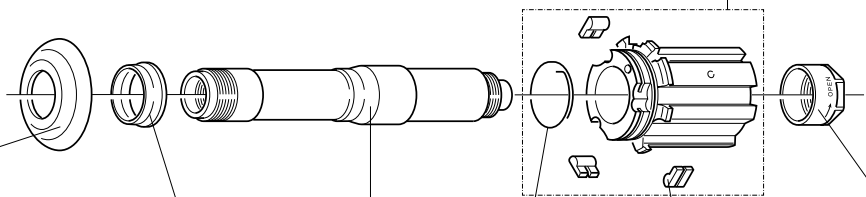
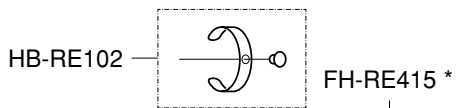
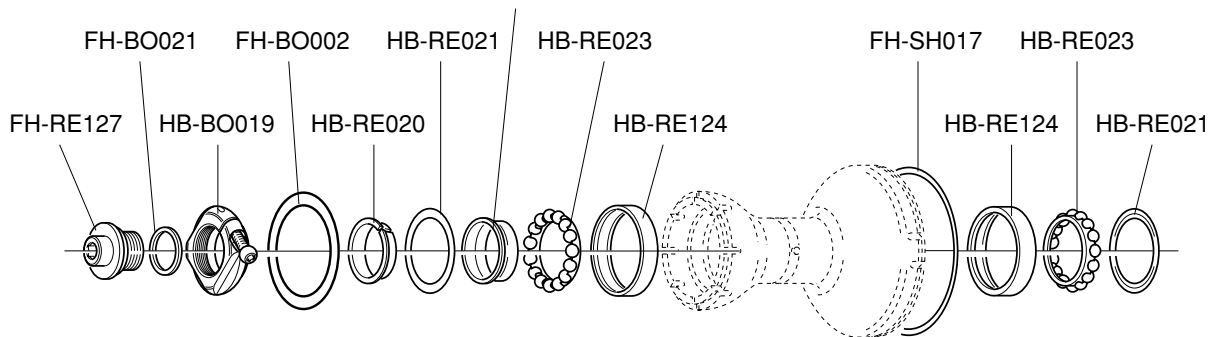

**NE/EU/HYP:** WH-009VE  
**ZO:** FH-SM009

**NE/EU/HYP:** FH-RE026  
**ZO:** FH-DA026

\* HG 8/9 type FW body / corpetto RL tipo HG 8/9: **WH-KX1** (RECORD type) **WH-KX2** (CHORUS type)

**MOZZO ANTERIORE  
PROTON  
FRONT HUB**

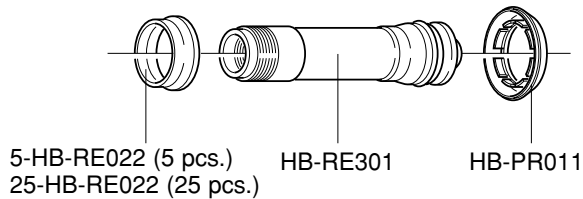
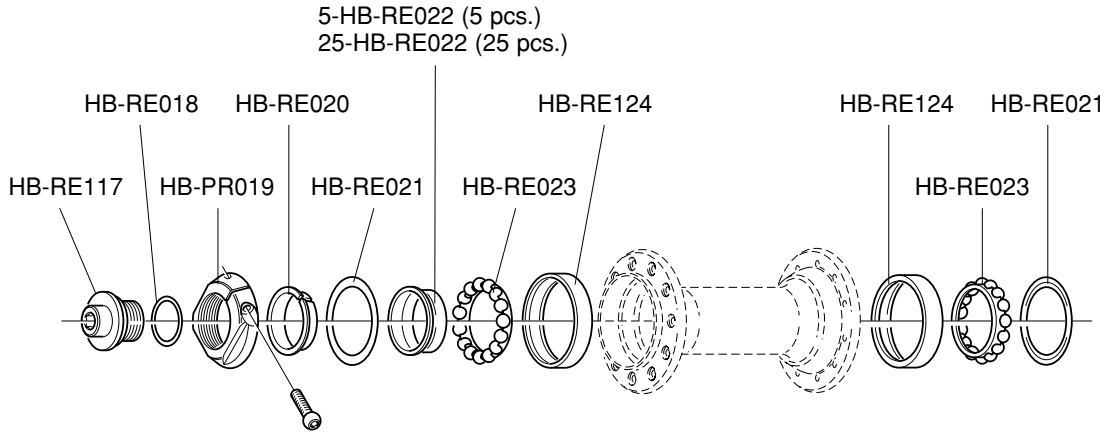

**MOZZO POSTERIORE 9s / 10s**  
**PROTON**  
**9s / 10s REAR HUB**

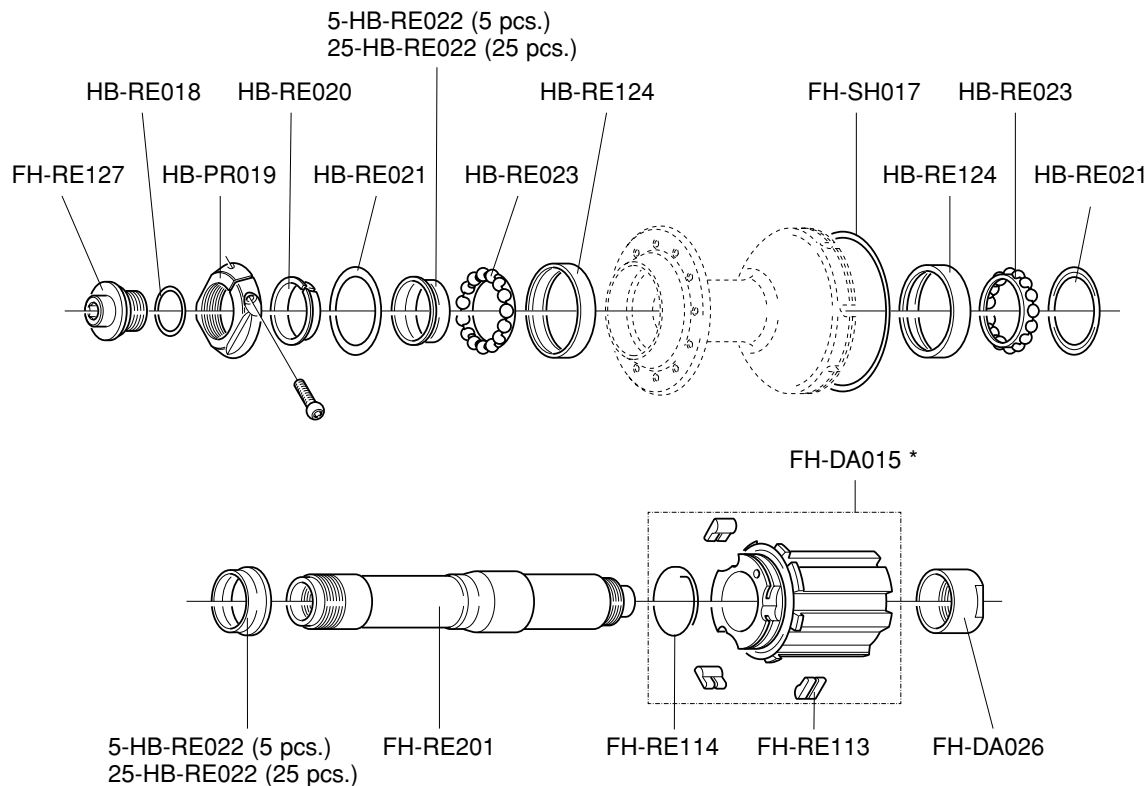

\* HG 8/9 type FW body / corpetto RL tipo HG 8/9: **WH-KX1** (RECORD type) **WH-KX2** (CHORUS type)



**MOZZO ANTERIORE  
e POSTERIORE  
*SCIROCCO*  
FRONT and REAR HUB**

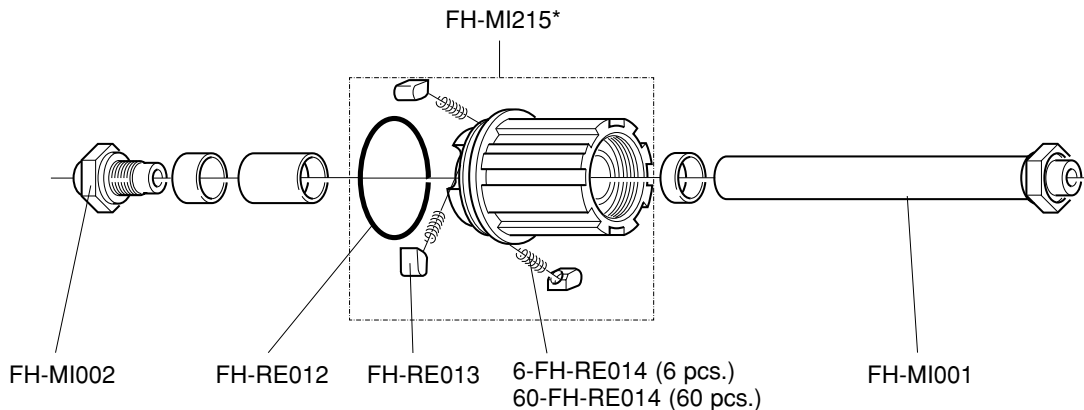
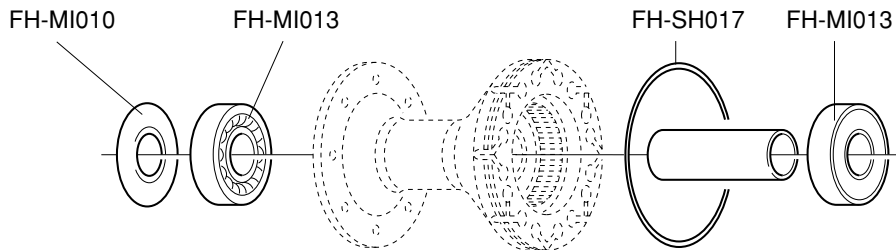
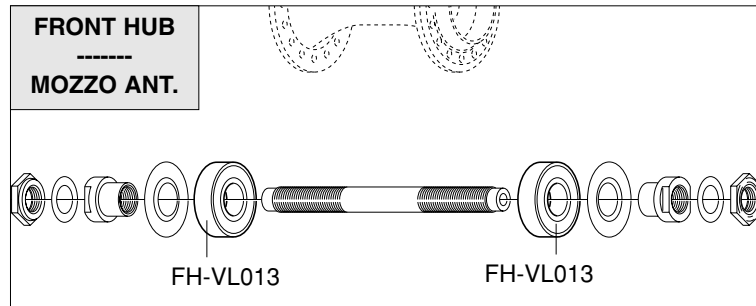

\* HG 8/9 type FW body / corpetto RL tipo HG 8/9: **WH-KX3**

**MOZZO ANTERIORE  
PISTA  
FRONT HUB**

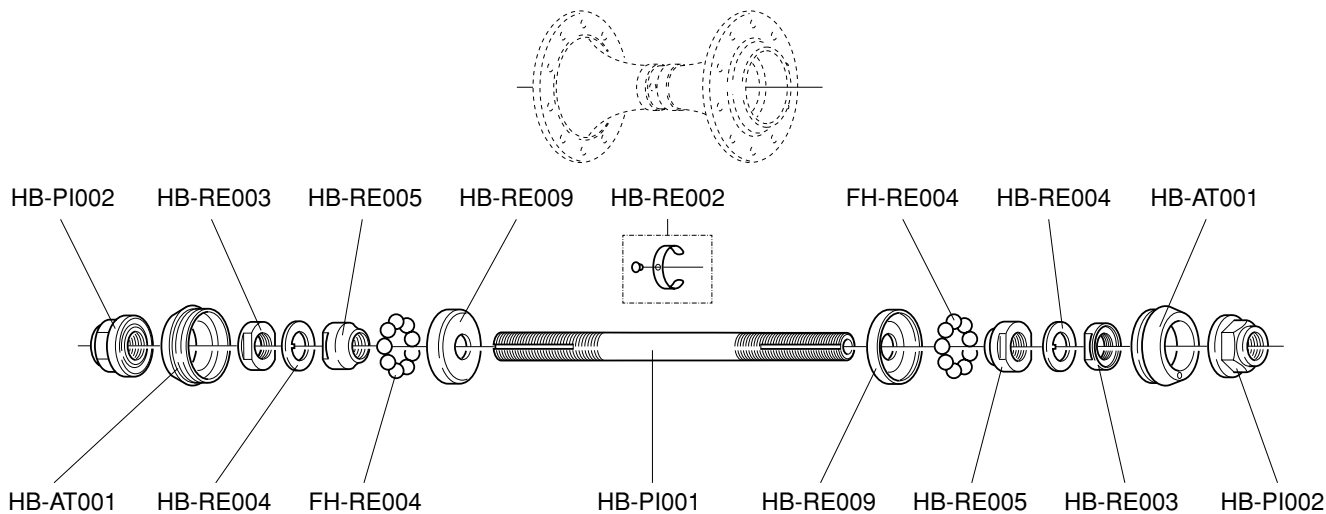

**MOZZO POSTERIORE**  
***PISTA***  
**REAR HUB**

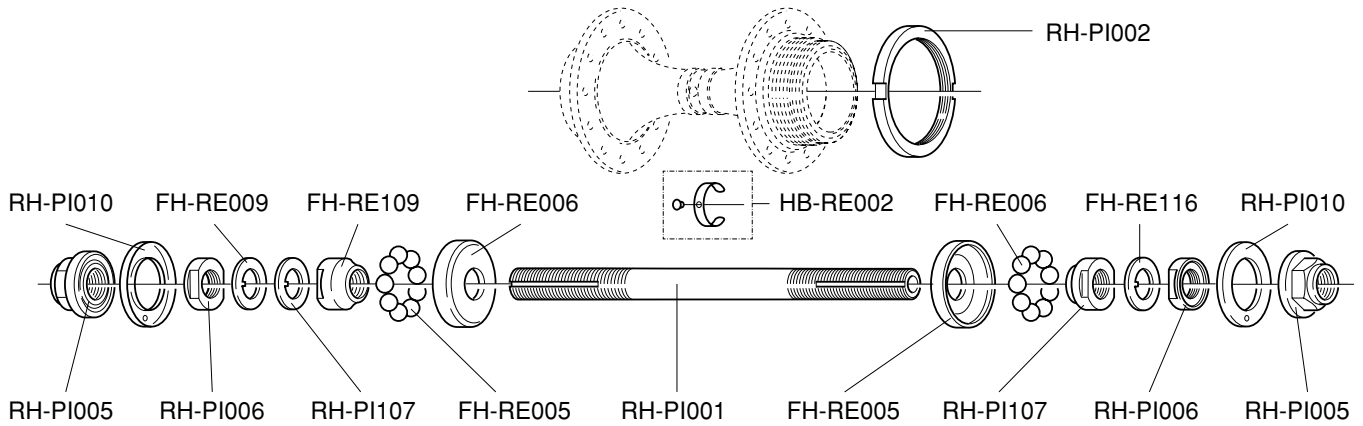

**MOZZO ANTERIORE  
e POSTERIORE  
*VENTO*  
FRONT and REAR HUB**

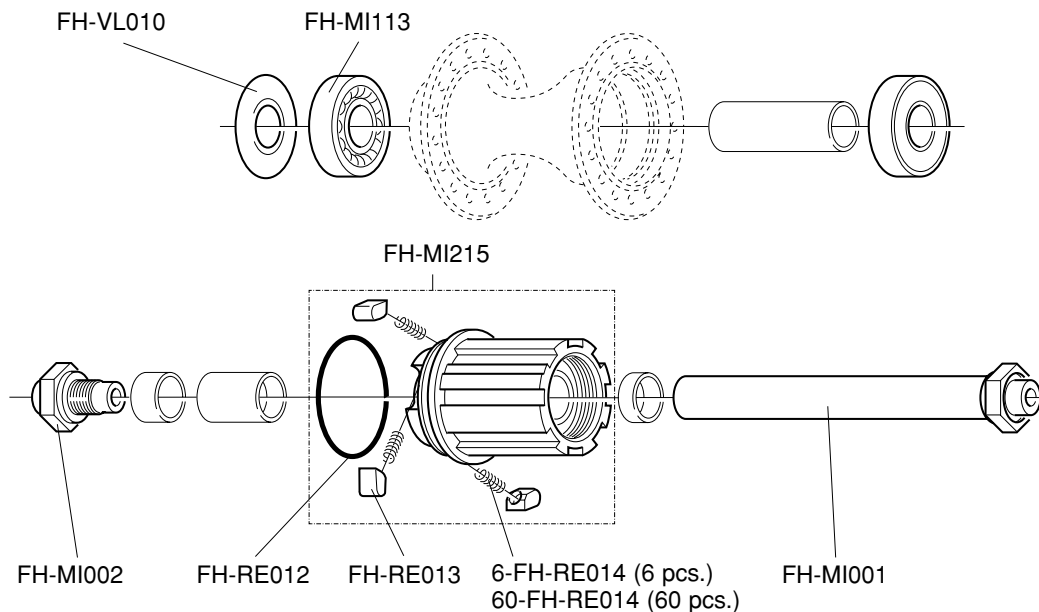
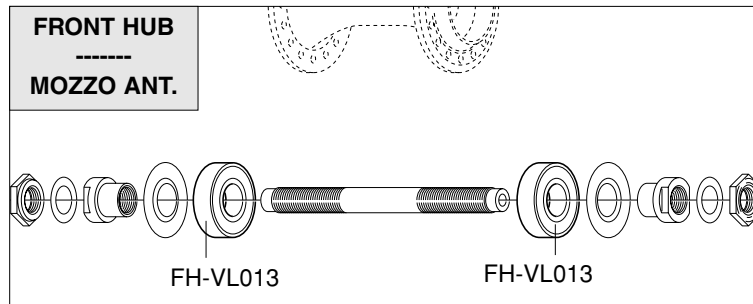

\* HG 8/9 type FW body / corpetto RL tipo HG 8/9: **WH-KX3**

## Utensili raccomandati reperibili in commercio

### Recommended tools, commercially available

---

- Cacciavite a croce PH 1 (Phillips)
  - Chiave a manico di cacciavite con esagono da 5mm per ruote:
    - Nucleon ed Electron
    - Shamal e Vento (solo da gamma '99 - per gamme precedenti vedi pag. 115)
  - Chiave a brugola da 2,5 mm per registrazione mozzi
  - Chiave a brugola da 3 mm per blocchetti fermaguaine
  - Chiave a brugola da 5 mm per freni, Ergopower, ecc.
  - Chiave dinamometrica con chiave a brugola da 8 mm per montaggio viti pedivelle
  - Chiave fissa da 17 mm per controdado mozzo posteriore
  - Chiave a bussola da 24 mm per utensile fissaggio calotte mov. centrale Daytona/Centaur, Veloce, Mirage (UT-BB100 - pag. 108)
  - Maschio M10 x 1 per ripasso occhiello attacco cambio su forcellini
  - Chiave TORX per viti fissaggio ingranaggi guarniture RECORD e CHORUS CARBON gamma 2004
- 
- Phillips type screwdriver
  - 5 mm nut driver for wheels:
    - Nucleon and Electron
    - Shamal and Vento (only from '99 range - for previous versions see page 115)
  - 2.5 mm allen key, for hub lock nut
  - 3 mm allen key, for downtube adjusters
  - 5 mm for brakes, Ergopower levers, etc.
  - Torque wrench fitted with 8 mm allen key
  - 17 mm hexagonal wrench, for rear hub axle nut
  - 24 mm hexagonal wrench for Daytona/Centaur, Veloce, Mirage bottom bracket tool (UT-BB100 on page 108)
  - M10 x 1 tap for recutting rear derailleur hanger thread
  - TORX wrench to fix the chainrings of the RECORD and CHORUS CARBON 2004 range cranksets

## HEADSET

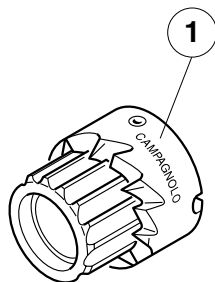

Doppia fresa sedi calotte per attrezzo UT-HS090 (Ø 1")

**UT-HS093:** standard

**UT-HS094:** con inserti in metallo duro

Double cutter cup seats for tool UT-HS090 (Ø 1")

**UT-HS093:** standard

**UT-HS094:** with hard metal inserts

Fraise double pour sièges cuvettes pour outil UT-HS090 (Ø 1")

**UT-HS093:** standard

**UT-HS094:** avec inserts métal dur

Doppelfräser für Gabelkonus für Werkzeug UT-HS090 (Ø 1")

**UT-HS093:** Standard

**UT-HS094:** mit aufgetragenen Hartmetallplättchen

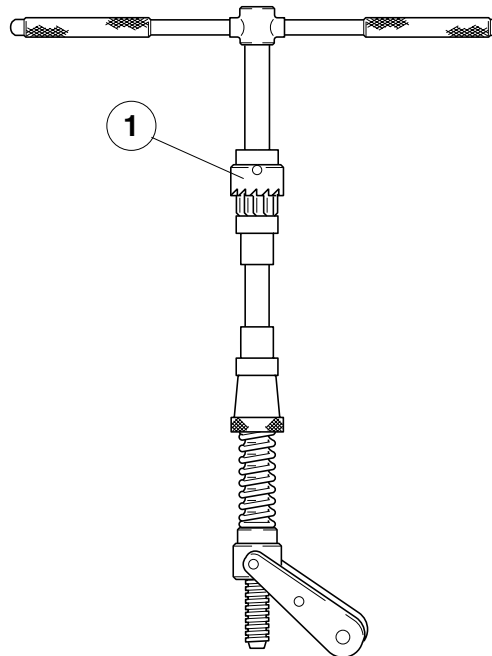

**UT-HS090:** Attrezzo fresatura tubo sterzo, montaggio calotta inferiore e cono superiore serie sterzo 1" - completo di doppia fresa standard (1)

**UT-HS090:** Tool for milling steering tube, for fitting bottom cup and top cone 1" headset - with standard double cutter (1)

**UT-HS090:** Outil pour fraisage tube de direction, montage cuvette inférieure et cône supérieur jeux de directions 1" - avec fraise double standard (1)

**UT-HS090:** Steuersatz-Fräswerkzeug - mit Standard-Doppelfräser (1) - für 1" Steuerschalensitz

## HEADSET

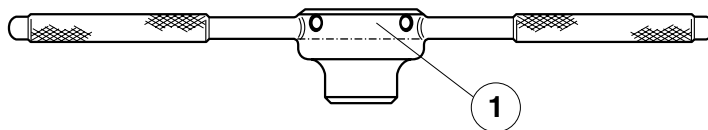

**UT-HS020:** Attrezzo per ripasso filetto forcelle per sterzi 1", con filiera (1)

**UT-HS020:** Tool for recutting fork thread for 1" Headsets, with threader (1)

**UT-HS020:** Outil pour repassage filetage fourche pour jeux de directions 1", avec filière (1)

**UT-HS020:** Werkzeug zum Nachschneiden von Gabelschaftgewinde, mit Gewinde-schneider (1), für Ø 1" Steuersatz

**UT-HS021:** Filiera per attrezzo ripasso forcella UT-HS020 (1")

**UT-HS021:** Cutter for recutting fork thread tool UT-HS020 (1")

**UT-HS021:** Filière pour outil repassage fourche UT-HS020 (1")

**UT-HS021:** Gewindeschneider für Werkzeug UT-HS020 (1") zum Nachschneiden für Gabelschaftrohr

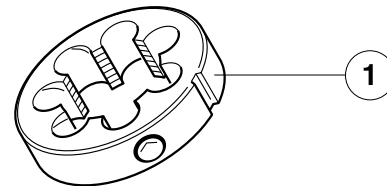

## HEADSET

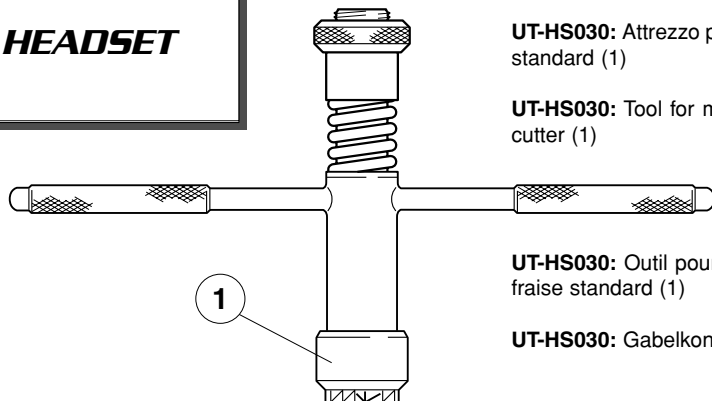

**UT-HS030:** Attrezzo per fresatura sede cono forcella per serie sterzo 1" con fresa standard (1)

**UT-HS030:** Tool for milling fork bottom cone seat for 1" headsets with standard cutter (1)

**UT-HS030:** Outil pour le fraisage siège cône de fourche pour directions 1" avec fraise standard (1)

**UT-HS030:** Gabelkonus-Fräswerkzeug für 1" Steuersitz mit Standardfräser (1)



**UT-HS110:** Attrezzo mont. cono forcella, per s. sterzo Hiddenset 1"  
**UT-HS120:** Attrezzo mont. cono forcella, per s. sterzo Hiddenset 1-1/8"

**UT-HS110:** Tool for installing fork cone, for Ø 1" Hiddenset headset  
**UT-HS120:** Tool for installing fork cone, for Ø 1-1/8" Hiddenset headset

**UT-HS110:** Outil pour montage cône de fourche, pour jeux de directions Hiddenset 1"  
**UT-HS120:** Outil pour montage cône de fourche, pour jeux de directions Hiddenset 1-1/8"

**UT-HS110:** Werkzeug zur Montage von Gabelkonus, für Ø 1" Hiddenset Steuersatz  
**UT-HS120:** Werkzeug zur Montage von Gabelkonus, für Ø 1-1/8" Hiddenset Steuersatz

Fresa per attrezzo UT-HS030 Ø 1"  
**UT-HS031:** standard  
**UT-HS032:** con inserti in metallo duro

Cutter for tool UT-HS030 Ø 1"  
**UT-HS031:** standard  
**UT-HS032:** with hard metal inserts

Fraise pour outil UT-HS030 Ø 1"  
**UT-HS031:** standard  
**UT-HS032:** avec inserts métal dur

Ø 1" Fräser für UT-HS030 Werkzeug  
**UT-HS031:** Standard  
**UT-HS032:** mit aufgetragenen Hartmetallplättchen

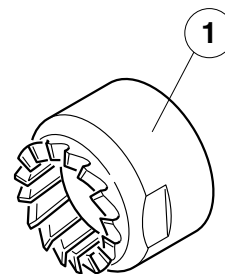



## HEADSET

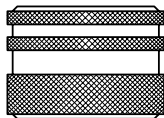

**UT-HS080:** Calibro controllo sede cono forcelle Ø 26,4 mm

**UT-HS080:** Gauge for checking fork cone seat 26,4 mm Ø

**UT-HS080:** Calibre de contrôle siège cône de fourche Ø 26,4 mm

**UT-HS080:** Kontrolllehre für Gabelkonussitz Ø 26,4 mm

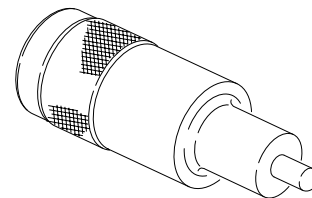

**UT-HS100:** Attrezzo montaggio serie sterzo Ø 1" per canotto non filettato

**UT-HS100:** Tool for installing Ø 1" headset for unthreaded steerers

**UT-HS100:** Outil pour montage jeu de direction Ø 1" pour tube de fourche non fileté

**UT-HS100:** Werkzeug zur Ø 1" Steuersatzmontage für gewindelosen Gabelschaft

## **HEADSET**

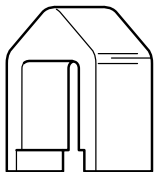

**UT-HS060:** Estrattore cono forcella serie sterzo

**UT-HS060:** Headset crown race remover

**UT-HS060:** Extracteur cône de fourche pour jeux de directions

**UT-HS060:** Abschläger für Gabelkonus für Steuersatz

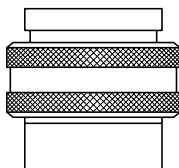

**UT-HS070:** Calibro controllo sedi coni e calotte sterzi 1"

**UT-HS070:** Gauge for checking cone and cup seats 1" headsets

**UT-HS070:** Calibre de contrôle sièges cônes et cuvettes jeux de directions 1"

**UT-HS070:** Kontrolllehre für Gabelkonus und 1" Steuerschalensitz

## HEADSET

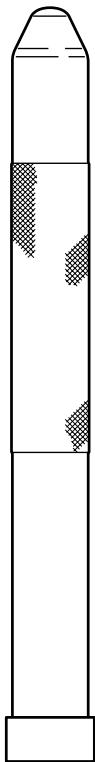

**UT-HS040:** Punzone per montaggio cono forcella, per serie sterzo Ø 1"

**UT-HS040:** Punch for installing fork cone, for Ø 1" headset

**UT-HS040:** Outil pour montage cône de fourche, pour jeux de directions Ø 1"

**UT-HS040:** Aufschläger für Montage von Gabelkonus, für Ø 1" Steuersatz

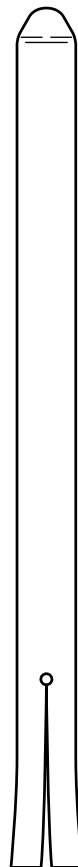

**UT-HS050:** Estrattore calotta inferiore e cono superiore, per serie sterzo Ø 1"

**UT-HS050:** Extractor for lower headset cup and race, for Ø 1" headset

**UT-HS050:** Extracteur cuvette inférieure et cône supérieur, pour jeux de directions Ø 1"

**UT-HS050:** Austreiber für oberen Konus und untere Lagerschale, für Ø 1" Steuersatz

## ***BOTTOM BRACKET***

**UT-BB045:** Maschio filetto italiano (1 pz.)

**UT-BB046:** Maschio filetto inglese destro (1 pz.)

**UT-BB047:** Maschio filetto inglese sinistro (1 pz.)

**UT-BB045:** Tap for Italian thread (1pc.)

**UT-BB046:** Tap for English thread right-hand (1pc.)

**UT-BB047:** Tap for English thread left-hand (1pc.)

**UT-BB045:** Taraud filetage italien (1 pc.)

**UT-BB046:** Taraud filetage anglais droit (1 pc.)

**UT-BB047:** Taraud filetage anglais gauche (1 pc.)

**UT-BB045:** ITA Gewindeschneider (1 St.)

**UT-BB046:** BSA Gewindeschneider rechts (1 St.)

**UT-BB047:** BSA Gewindeschneider links (1 St.)

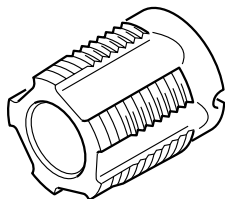

Attrezzo per filettatura scatola movimento centrale con 2 maschi

**UT-BB040:** Filetto italiano

**UT-BB041:** Filetto inglese

Tool for threading bottom bracket housing with 2 taps

**UT-BB040:** Italian thread

**UT-BB041:** English thread

Outil pour le filetage de la boîte de pédalier avec 2 tarauds

**UT-BB040:** filetage italien

**UT-BB041:** filetage anglais

Tretlager-Gewindeschneid-Werkzeug mit 2 Gewindeschneider mit:

**UT-BB040:** ITA Gewinde

**UT-BB041:** BSA Gewinde

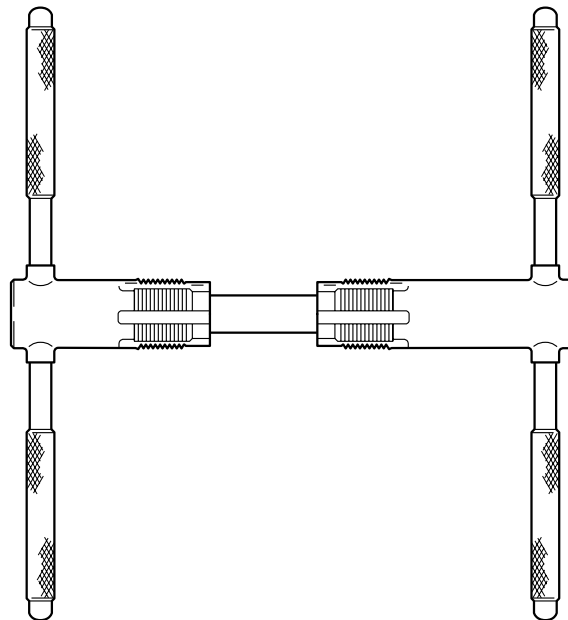

## **BOTTOM BRACKET**

**UT-BB052:** 2 manicotti filettati di guida per attrezzo UT-BB050, italiano

**UT-BB053:** 2 manicotti filettati di guida per attrezzo UT-BB051, inglese

**UT-BB052:** Inner and outer thread guide for UT-BB050, IT thread

**UT-BB053:** Inner and outer thread guide for UT-BB051, BSC thread

**UT-BB052:** 2 manchons filetés de guide pour outils UT-BB050 fil. Italien

**UT-BB053:** 2 manchons filetés de guide pour outils UT-BB051 fil. anglais

**UT-BB052:** 2 Gewindemuffen zur Führung Werkzeuge UT-BB050, ITA

**UT-BB053:** 2 Gewindemuffen zur Führung Werkzeuge UT-BB051, BSA

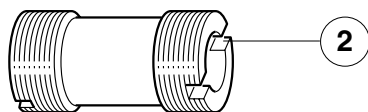

Fresa per attrezzi UT-BB050 e UT-BB051

**UT-BB054:** Fresa standard

**UT-BB055:** Fresa con inserti metallo duro

Cutter for tools UT-BB050 and UT-BB051

**UT-BB054:** standard cutter

**UT-BB055:** cutter with hard metal inserts

Attrezzo fresatura piani scatola movimento centrale con fresa standard (1) e 2 manicotti filettati (2)

**UT-BB050:** Filetto italiano

**UT-BB051:** Filetto inglese

Bottom bracket facing set with standard cutter (1) and 2 - inner and outer - thread guide (2)

**UT-BB050:** Italian thread

**UT-BB051:** English thread

Outil fraisage faces boîte de pédalier avec fraise standard (1) et 2 manchons filetés de guide (2)

**UT-BB050:** filetage italien

**UT-BB051:** filetage anglais

Werkzeug zum Planfräsen des Tretlagergehäuses mit Standardfräse (1) und 2 Gewindemuffe (2)

**UT-BB050:** für ITA Gewinde

**UT-BB051:** für BSA Gewinde

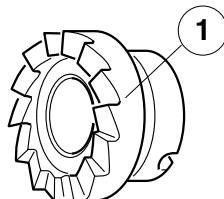
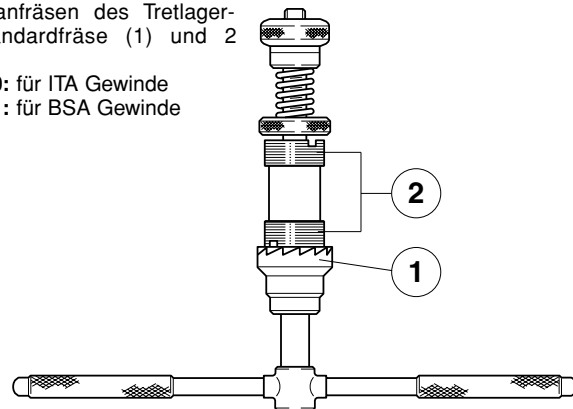

Fresa per attrezzi UT-BB050 e UT-BB051

**UT-BB054:** Fresa standard

**UT-BB055:** Fresa con inserti metallo duro

Cutter for tools UT-BB050 and UT-BB051

**UT-BB054:** standard cutter

**UT-BB055:** cutter with hard metal inserts

## **BOTTOM BRACKET**

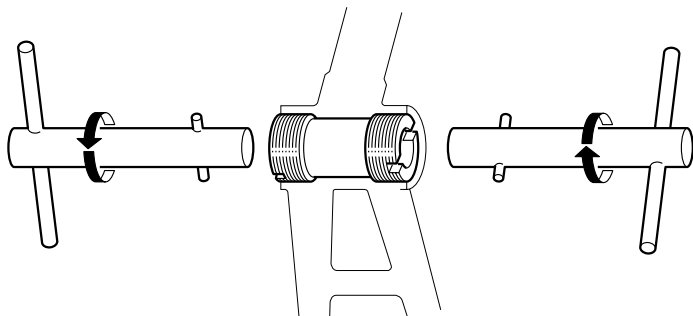

**UT-BB060:** Chiave per montaggio manicotti attrezzi UT-BB050/UT-BB051 (1 pz.)

**UT-BB060:** Key for BB-thread guides UT-BB050/UT-BB051 (1 pcs.)

**UT-BB060:** Clé pour montage guides pour outils UT-BB050/UT-BB051 (1 pcs.)

**UT-BB060:** Rohrschlüssel für Tretlagergewinde-Führungsteile UT-BB050/UT-BB051 (1 Stück)

**UT-BB080** (1 pz.) - **10-UT-BB080** (10 pz.): Chiave per montaggio movimenti centrali CART e ghiere di chiusura pacchi pignoni

**UT-BB080** (1 pc.) - **10-UT-BB080** (10 pcs.): Cartridge bottom bracket and sprocket cassette- lock ring remover

**UT-BB080** (1 pc.) - **10-UT-BB080** (10 pcs.): Clé pour montage jeux de pédalier CART et roues-libres à cassette

**UT-BB080** (1 St.) - **10-UT-BB080** (10 St.): Schlüssel zur Montage von Patronen-Tretlager und Schließring für Freilaufzahnkranz

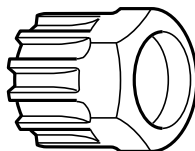

## ***BOTTOM BRACKET***

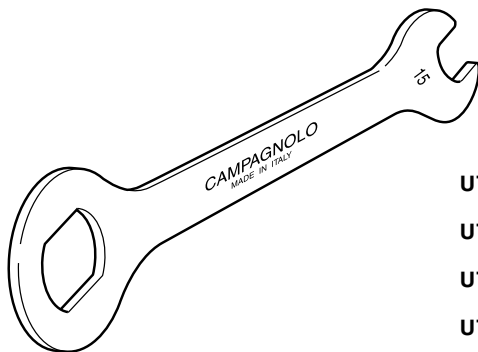

**UT-BB030:** Chiave per calotta destra movimenti centrali e per montaggio pedali

**UT-BB030:** Spanner for bottom bracket right-hand cup and installing pedals

**UT-BB030:** Clé pour cuvette droite jeu de pédalier et montage pédales

**UT-BB030:** Schlüssel für rechte Innenlagerschalen und Pedal-Montage

**UT-BB100:** Utensile per movimenti a cartuccia Daytona/Centaur, Veloce e Mirage

**UT-BB100:** Tool for Daytona/Centaur, Veloce and Mirage cartridge bottom bracket

**UT-BB100:** Clé pour jeux de pédalier à cartouche Daytona/Centaur, Veloce et Mirage

**UT-BB100:** Montageschlüssel für Daytona/Centaur, Veloce und Mirage Patronen-Tretlager

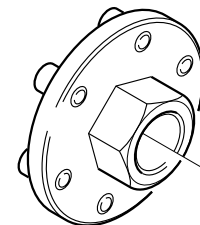

## **HEADSET / BOTTOM BRACKET**



**UT-BB010:** Chiave per serie sterzo Ø 1" e calotta sinistra movimento centrale Pista

**UT-BB010:** Spanner for Ø 1" head sets and Pista bottom bracket left hand cup

**UT-BB010:** Clé pour direction Ø 1" et cuvette réglable jeu de pédalier Pista

**UT-BB010:** Schlüssel für Ø 1" Steuersatz und Stiftschlüssel für Pista Tretlagerschale

**UT-BB011:** Punta per chiave UT-BB010

**UT-BB011:** Pin for UT-BB010

**UT-BB011:** Grain pour clé UT-BB010

**UT-BB011:** Stift für Schlüssel UT-BB010

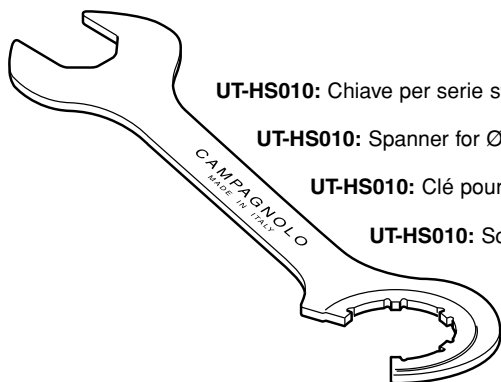

**UT-HS010:** Chiave per serie sterzo Ø 1" e contranello movimento centrale Pista

**UT-HS010:** Spanner for Ø 1" head sets and Pista bottom bracket counter ring

**UT-HS010:** Clé pour direction Ø 1" et contre-écrou du jeu de pédalier Pista

**UT-HS010:** Schlüssel für Ø 1" Steuersatz und Pista Tretlager-Konterring



## FRAME PREPARATION

**UT-VS060:** Maschio M3 x 0,5 per ripasso filetti forcellini per viti registrazione

**UT-VS060:** M3 x 0,5 tap for recutting rear drop-out threads for setting screws

**UT-VS060:** Taraud M3 x 0,5 pour repassage filetage pattes de cadre pour vis de réglage

**UT-VS060:** M3 x 0,5 Gewindebohrer zum Nachschneiden von Stellschraubengewinde im Ausfallende

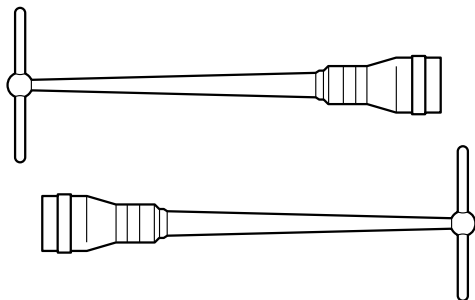
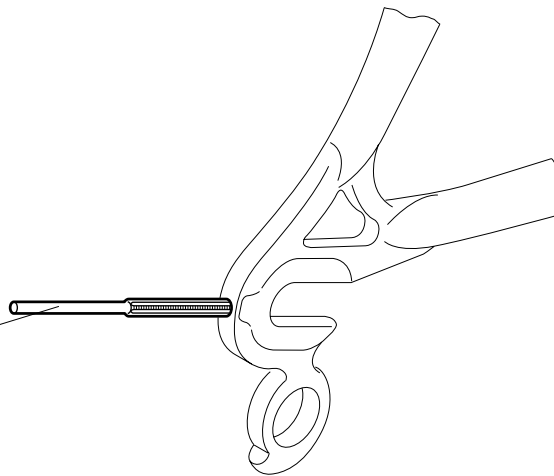

**UT-VS120:** Calibro per controllo allineamento forcellini e punte forcelle (2 pz.)

**UT-VS120:** Drop-out alignment set (2 pcs.)

**UT-VS120:** Calibre pour contrôle alignement pattes de cadres et pattes de fourches (2 pcs.)

**UT-VS120:** Werkzeug zum Ausrichten von Gabel- und Ausfallenden (2 St.)

## **FRAME PREPARATION**

**UT-VS050:** Maschio M5 x 0,8 per ripasso filetti attacchi quadri comandi e attacchi borracce

**UT-VS050:** M5 x 0,8 tap for recutting shifting lever- and bottle cage threads

**UT-VS050:** Taraud M5 x 0,8 pour repassage filetage plots de manettes et attaches bidons

**UT-VS050:** M5 x 0,8 Gewindebohrer zum Nachschneiden der Gewinde für Schalthebel und Trinkflaschenhalter

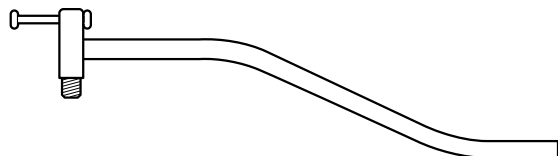
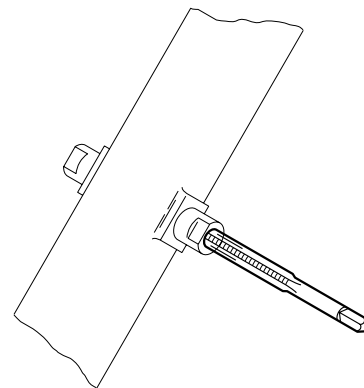

**UT-VS030:** Riscontro allineamento occhiello attacco cambio

**UT-VS030:** Rear derailleur hanger alignment tool

**UT-VS030:** Calibre de contrôle attache de dérailleur arrière

**UT-VS030:** Richtwerkzeug zur Kontrolle von Ausfallende mit Schaltauge

## **CRANKS / CHAINRINGS**

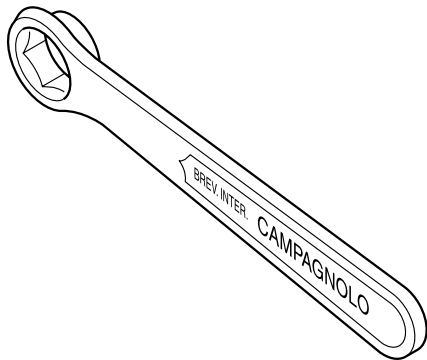

**UT-FC050:** Chiave con esagono da 15 mm per estrattore pedivelle

**UT-FC050:** 15 mm crank bolt spanner

**UT-FC050:** Clé avec hexagone de 15 mm pour extracteur manivelles

**UT-FC050:** 15 mm Schlüssel für Tretkurbelabzieher

**UT-FC060:** Estrattore pedivelle standard

**UT-FC070:** Estrattore pedivelle con filetto a sinistra

**UT-FC060:** Extractor for standard cranks

**UT-FC070:** Extractor for cranks with l.h. thread

**UT-FC060:** Extracteur manivelles standards

**UT-FC070:** Extracteur manivelles avec filetage à gauche

**UT-FC060:** Standard - Tretkurbelabzieher

**UT-FC070:** Tretkurbelabzieher mit Linksgewinde

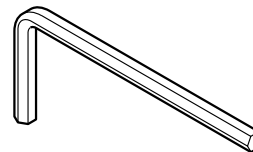
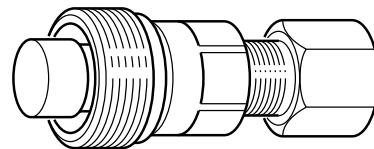

**UT-FC030:** Chiave a brugola da 5 mm

**UT-FC030:** 5 mm allen key

**UT-FC030:** Clé à pans creux de 5 mm

**UT-FC030:** 5 mm L-Schlüssel

**CRANKS /  
CHAINRINGS /  
BRAKES**

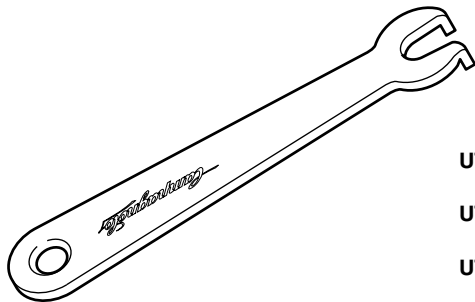

**UT-FC040:** Chiave per dadi fissaggio ingranaggi

**UT-FC040:** Spanner for chainring retaining nuts

**UT-FC040:** Clé pour écrous de fixation plateaux de pédaliers

**UT-FC040:** Schlüssel zur Befestigung von Kettenblattbolzen

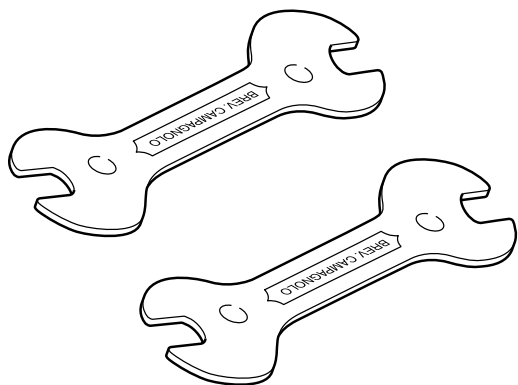

**UT-BR010:** Coppia chiavi 13-14 per registrazione freni e coni mozzi

**UT-BR010:** Pair of 13-14 mm spanners for adjusting brakes and hub cones

**UT-BR010:** Paire clés 13-14 pour réglage freins et cônes de moyeux

**UT-BR010:** 13-14 mm Schlüssel (2 Stücke) zum Einstellen von Bremsen und Nabelkonusen

## HUBS & WHEELS

**UT-HU090:** Attrezzo per montaggio cricchetti ruota libera su mozzi standard e HPW

**UT-HU090:** freewheel-pawl assembling tool (standard and HPW-hubs)

**UT-HU090:** Outil pour montage cliquets de roue-libre sur moyeux standard et HPW

**UT-HU090:** Werkzeug zur Montage der Kassettenkörper-Sperrklinken (Standard- und HPW-Nabe)

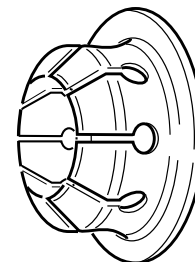

**UT-HU020:** Pinza per perni filettati mozzi

**UT-HU020:** Hub axle vise

**UT-HU020:** Pince pour axes filetés de moyeux

**UT-HU020:** Klemmvorrichtung für Naben-Achsgewinde

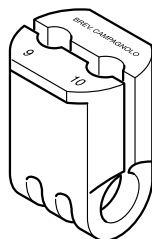

**UT-HU050:** Tiraraggi

**UT-HU050:** Spoke wrench

**UT-HU050:** Clé à rayons

**UT-HU050:** Speichenschlüssel

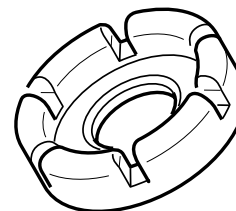

## **HUBS & WHEELS**

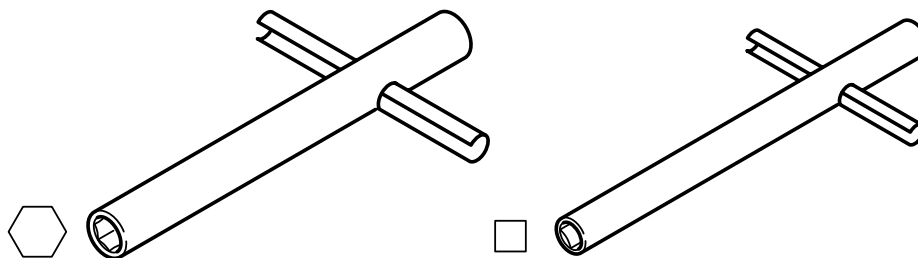

**UT-HU070:** Chiave per raggi ruote Shamal, Vento e Zonda (fino a gamma '98 - per gamma '99 e successive vedi pag. 98)

**UT-HU070:** Shamal, Vento and Zonda wheel truing tool (till '98 range - from '99 range see page 98)

**UT-HU070:** Clé à rayons pour roues Shamal, Vento et Zonda (jusqu'à la gamme '98 - pour la gamme '99 et suivantes v. page 98)

**UT-HU070:** Nippelspanner für Shamal, Vento und Zonda (bis '98 Produktlinie - ab '99 Produktlinie siehe S. 98)

**UT-HU060:** Chiave per raggi ruote Bora

**UT-HU060:** Bora wheel truing tool

**UT-HU060:** Clé à rayons pour roues Bora

**UT-HU060:** Vierkant-Nippelspanner für Bora

**HUBS &  
WHEELS**

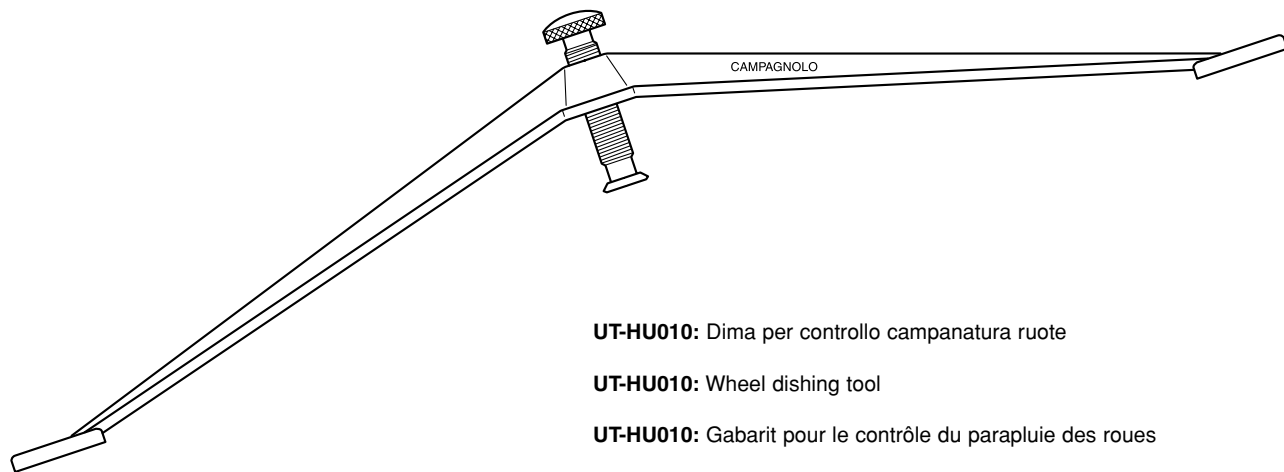

**UT-HU010:** Dima per controllo campanatura ruote

**UT-HU010:** Wheel dishing tool

**UT-HU010:** Gabarit pour le contrôle du parapluie des roues

**UT-HU010:** Zentrierbügel

## **SPROCKETS / CHAIN**

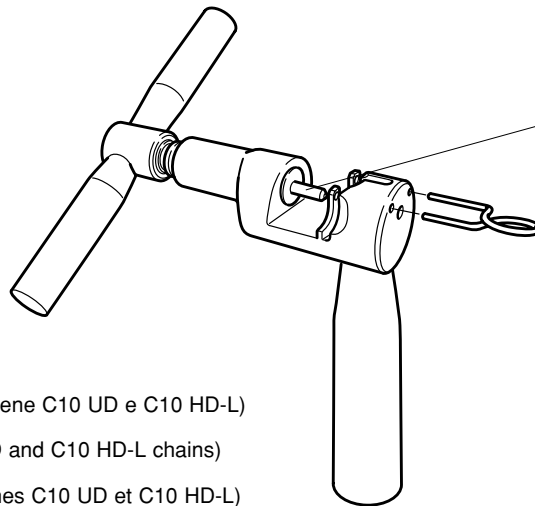

**UT-CN201:** Spintore per UT-CN200

**UT-CN201:** Pusher for UT-CN200

**UT-CN201:** Poinçon pour UT-CN200

**UT-CN201:** Schieber für UT-CN200

**UT-CN200:** Utensile per **HD-Link** (catene C10 UD e C10 HD-L)

**UT-CN200:** Tool for **HD-Link** (C10 UD and C10 HD-L chains)

**UT-CN200:** Outil pour **HD-Link** (chaînes C10 UD et C10 HD-L)

**UT-CN200:** Werkzeug für **HD-Link** (C10 UD und C10 HD-L Ketten)

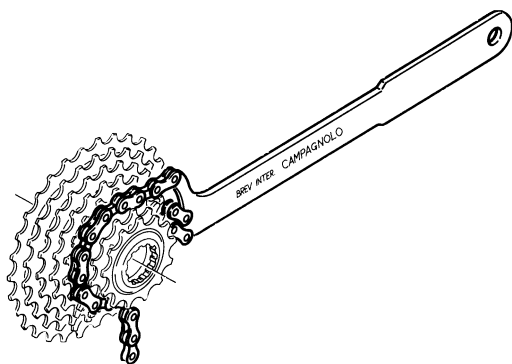

**UT-CS060:** Chiave con catena 10s per smontaggio pignoni 10s, 9s e 8s

**UT-CS060:** Spanner with 10s chain for 10, 9 and 8s sprockets

**UT-CS060:** Fouet à chaîne 10s pour pignons 10s, 9s et 8s

**UT-CS060:** Zahnkranzabnehmer mit Rennkette 10s für 10-, 9- und 8s Ritzeln



**ITALY - Central Service Center****CAMPAGNOLO SRL HEADQUARTERS**

Via della Chimica, 4 - 36100 VICENZA  
 Phone: +39-0-444-225605  
 Fax: +39-0-444-225400  
 E-mail: service@campagnolo.com

**AUSTRALIA****BIKE SPORTZ IMPORTS PTY LTD**

23c-23d Industrial Drive,  
 Braeside, Victoria 3195 NSW  
 Phone: +61-3-95861600  
 Fax: +61-3-98576951

**CYCLING PROJECTS**

80 King Street,  
 NSW 2193 Ashbury  
 Phone: +61-2-97992407  
 Fax: +61-2-97879940

**AUSTRIA****CAMPAGNOLO DEUTSCHLAND GMBH**

An der Schusterinsel, 15  
 51379 LEVERKUSEN - DEUTSCHLAND  
 Phone: +49-2171-724320  
 Fax: +49-2171-724315

**BENELUX****CARD BENELUX BV**

Vaartveld 19 - 4704 SE ROOSENDAAL  
 Netherlands  
 Phone: +31-165-564241  
 Fax: +31-165-563248

**BENELUX (continued)****FA. WOUT VERHOEVEN**

Rodenrijseweg 409 -  
 2651 AM BERKEL EN RODENRIJS - Netherlands  
 Phone: +31-10-5115014  
 Fax: +31-10-5117708

**I.C.C. - INTERNATIONAL CYCLE CONNECTION**

Weststraat 42 - P.O. Box 73  
 4527 ZH AARDENBURG - Netherlands  
 Phone: +31-117-492820  
 Fax: +31-117-492835

**CANADA****CYCLES MARINONI INC**

1067, Levis - LACHENAIE - QUEBEC J6W 4L2  
 Phone: +1-450-4717133  
 Fax: +1-450-4719887

**GREAT WESTERN BICYCLE CO. LTD.**

233 West Broadway  
 VANCOUVER BC V5Y 1P5  
 Phone: +1-604-8722424  
 Fax: +1-604-87202226

**CZECH REPUBLIC****KOLA SIRER**

P.O. Box 107 - 26601 BEROUN 1  
 Phone: 00420-311-621355  
 Fax: 00420-311-625492

**DENMARK****MARKER SCANDINAVIA**

Industrivej 1D - DK-4000  
 Roskilde - DENMARK  
 Phone: +45-70228075  
 Fax: +45-46498088

**FINLAND****MARKER SCANDINAVIA**

Industrivej 1D - DK-4000  
 Roskilde - DENMARK  
 Phone: +45-70228075  
 Fax: +45-46498088

**VELOSPORT KY**

Mäkelänkatu, 95 - 00610 HELSINKI P  
 Phone: +358-9-7571377  
 Fax: +358-9-795498

**FRANCE****CAMPAGNOLO FRANCE**

42160 ANDREZIEUX - BOUTHEON CEDEX  
 Phone: +33-477-556305  
 Fax: +33-477-556345

**GERMANY****CAMPAGNOLO DEUTSCHLAND GMBH**

An der Schusterinsel, 15  
 51379 LEVERKUSEN  
 Phone: +49-2171-724320  
 Fax: +49-2171-724315

**GREECE****CYCLES FIDUSA**

Th. Sofuli 97 - 85100 RHODOS  
 Phone: +30-241-021264  
 Fax: +30-241-021519

**JAPAN****KAWASHIMA CYCLE SUPPLY CO.**

No. 3-3-16 Kitasho-cho, Sakai,  
 Osaka, 590-0007  
 Phone: +81-722-38-6126  
 Fax: +81-722-21-4379

---

**JAPAN** (continued)

---

**NICHINAO SHOKAI CO., LTD**

6-16-8, Sotokanda, Chiyodaku - TOKYO 101  
Phone: +81-3-38326251  
Fax: +81-3-38326266

---

**NEW ZEALAND**

---

**WH WORRALL CO. LTD.**

43 Felix St./Penrose - P.O. Box 12481  
AUCKLAND  
Phone: +64-9-6360641  
Fax: +64-9-6360631

---

**NORWAY**

---

**MARKER SCANDINAVIA**

Industrivej 1D - DK-4000  
Roskilde - DENMARK  
Phone: +45-70228075  
Fax: +45-46498088

---

**SOUTH AFRICA**

---

**CYCLING J&J (PTY) LTD**

169 Meerlust Street - Willow Glen  
PRETORIA  
Phone: +27-012-8075570  
Fax: +27-012-8074267

---

**SPAIN**

---

**CAMPAGNOLO IBERICA S.L.**

Avda. de Los Huetos 46 Pab. 31 - 01010  
VITORIA  
Phone: +34-945-217195  
Fax: +34-945-217198

---

---

**SWEDEN**

---

**MARKER SCANDINAVIA**

Industrivej 1D - DK-4000  
Roskilde - DENMARK  
Phone: +45-70228075  
Fax: +45-46498088

---

**RACERDEPAN**

Odengatan, 38 - 52141 FALKÖPING  
Phone: +46-515711430  
Fax: +46-51559430

---

---

**SWITZERLAND**

---

**PIERO ZURINO AG**

Flawilerstrasse 3a  
9500 WIL SG  
Phone: +41-71-9236001  
Fax: +41-71-9236353

---

**U.G.D. SPORT DIFFUSION S.A.**

La Taille - 2053 CERNIER  
Phone: +41-32-8536363  
Fax: +41-32-8536464

---

---

**UNITED KINGDOM**

---

**ITALIAN CYCLE PRODUCTS LIMITED**

Unit 3, Napoleon Business Park  
Wheterby Road - DERBY - DE24 8HL  
Phone: +44-01332-371176  
Fax: +44-01332-371179

---

---

**UNITED STATES**

---

**CAMPAGNOLO USA INC.**

2105-L Camino Vida Roble  
CARLSBAD - CA 92009  
Phone: +1-760-9310106  
Fax: +1-760-9310991

---

**OCHSNER INT. INC**

246 E. Marquardt Drive - WHEELING  
IL. 60090-6430  
Phone: +1-847-4658200  
Fax: +1-847-4658282

---

**QUALITY BICYCLES PRODUCTS**

6400 W. 105th Street - BLOOMINGTON,  
MN 55438-2554  
Phone: +1-952-941-9391  
Fax: +1-952-941-9799

---

### **Avviso Importante su PRESTAZIONI, SICUREZZA E GARANZIA**

I componenti delle trasmissioni 9s e 10s, gli impianti frenanti, e la maggior parte dei componenti Campagnolo®, sono progettati come un unico sistema integrato. Per non compromettere la SICUREZZA, le PRESTAZIONI, la LONGEVITA', la FUNZIONALITA' e per non invalidare la GARANZIA, vi raccomandiamo di utilizzare **esclusivamente** i componenti specificati dalla Campagnolo Srl, senza interfacciarli o sostituirli con prodotti fabbricati da altre aziende.

### **Important PERFORMANCE, SAFETY and WARRANTY Notice**

The components of the 9s and 10s drivetrains, the braking systems, and most Campagnolo® components, are designed as a single integrated system. To avoid compromises in terms of SAFETY, PERFORMANCE, DURABILITY, FUNCTION, and to prevent voiding the WARRANTY, we recommend that you **only** use the components specified by Campagnolo Srl, without interfacing them with or substituting them with products manufactured by other companies.

### **Notice important sur PERFORMANCES, SECURITE ET GARANTIE**

Les composants des transmissions 9s et 10s, les freins et la plus part des composants Campagnolo®, sont projetés come un seul système intégré. Pour ne pas compromettre la SECURITE, les PERFORMANCES, la LONGEVITE, la FONCTIONNALITE et pour ne pas invalider la GARANTIE, on vous recommande **de n'utiliser que** les composants spécifiés par Campagnolo Srl, sans les relier avec ou les remplacer par des produits fabriqués par d'autres sociétés.

### **Wichtiger Hinweis zu PRODUKTLEISTUNG, SICHERHEIT und GARANTIE**

Die Komponenten der 9s und 10s Antriebssysteme, des Bremssystems, sowie Großteil der von Campagnolo® hergestellten Komponenten, wurden als Bestandteile eines integrierten Systems entwickelt. Um die SICHERHEIT, die LEISTUNG, die DAUER, die FUNKTIONSTÜCHTIGKEIT und die GARANTIE nicht zu beeinträchtigen, empfehlen wir den **ausschließlichen** Gebrauch der von Campagnolo Srl spezifizierten Bestandteile und diese nicht mit Produkten anderer Hersteller zu ersetzen oder zu kombinieren.

### **Avviso Importante sobre PRESTACIONES, SEGURIDAD Y GARANTÍA.**

Los componentes de las transmisiones 9s y 10s, los sistemas de frenado, y la mayor parte de componentes Campagnolo®, han sido ideados como un único sistema integrado. Con el fin de no comprometer la SEGURIDAD, las PRESTACIONES, la LONGEVIDAD, la FUNCIONALIDAD y no invalidar la GARANTÍA, os aconsejamos utilizar **exclusivamente** los componentes especificados por Campagnolo Srl, sin combinarlos o sustituirlos con productos fabricados por otras empresas.

Campagnolo, Campy, Record, Chorus, EPS, Centaur, Centaur Century Grey, Veloce, Mirage, Xenon, Hyperon, Hyperon Ultra, Neutron, Proton, Eurus, Zonda, Scirocco, Bora, Ghibli, Vento, Pista, Ergobrain, Ergobrain10, Superlative, Ultra, Floating-Link-Action, HD-Link, HD-L, Exa-Drive, Ultra-Drive, Pro-Fit, Pro-Fit PLUS, Differential brakes, Threadless, Hiddenset, Hiddenset TTC, TTC, Ergopower, BB System, C10, C9, ED, UD, HPW, G3, Ultralinear-Geometry, Ultralinear, Differential rims, Differential spokes, Asymmetric, AC-H, AC-S, SC-S, Pro-Shop, Tecnologia ed Emozione are Campagnolo Srl Trademarks.



# CAMPAGNOLO IN THE WORLD

## ITALY

CAMPAGNOLO S.R.L.

Via della Chimica, 4 • 36100 Vicenza • ITALY

Phone: +39-0444-225500 • Fax: +39-0444-225400

## FRANCE

CAMPAGNOLO FRANCE SARL

Rue Jean Autelin • B.P. 148 • 42160 Andrézieux • Bouthéon

Cedex • FRANCE

Phone: +33-477-556305 • Fax: +33-477-556345

## GERMANY

CAMPAGNOLO DEUTSCHLAND GMBH

An der Schusterinsel 15 • 51379 Leverkusen • GERMANY

Phone: +49-2171-72430 • Fax: +49-2171-724315

## SPAIN

CAMPAGNOLO IBERICA S.L.

Avda. de Los Huetos 46 Pab. 31 • 01010 Vitoria • SPAIN

Phone: +34-945-217195 • Fax: +34-945-217198

## UNITED STATES

CAMPAGNOLO USA INC.

2105-L Camino Vida Roble • Carlsbad CA 92009 • U.S.A.

Phone: +1-760-9310106 • Fax: +1-760-9310991

## SERVICE AND TECHNICAL INFORMATION:

### ITALY (CENTRAL)

Technical Information: Phone: +39-0444-225600 •

Fax: +39-0444-225400

Service Center: Phone: +39-0444-225605 •

Fax: +39-0444-225400

### FRANCE

Phone: +33-477-554449 • Fax: +33-477-556345

### GERMANY

Phone: +49-2171-724320 • Fax: +49-2171-724315

### SPAIN

Phone: +34-945-217195 • Fax: +34-945-217198

### U.S.A.

Phone: +1-760-9310106 • Fax: +1-760-9310991

## AGENCIES

### AUSTRALIA

CYCLING PROJECTS

80 King Street • NSW 2193 Ashbury • AUSTRALIA •

Tel. +61-2-97992407 • Fax +61-2-97879940

### BENELUX

INTERNATIONAL CYCLE CONNECTION • I.C.C. • Weststraat 42

P.O. Box 73 • 4527 ZH Aardenburg • NEDERLAND •

Tel. +31-11-7492820 • Fax +31-11-7492835

### BULGARIA • CZECH REPUBLIC • POLAND • RUMANIA SLOVAKIAN REPUBLIC • SLOVENIA • HUNGARY

FIRMA GALLIZIA

10. Oktoberstraße 7 • 9800 Spittal/Drau • AUSTRIA •

Tel. +43-4762/2275 • Fax +43-4762/2275

### DENMARK • SWEDEN • NORWAY • FINLAND

MARKER SCANDINAVIA

Industrivej 1D • DK-4000 ROSKILDE • DENMARK •

Tel.: +45-70228075 • Fax: +45-46498088

### RUSSIA

VLADISLAV BOBRIK

Mob.: 335 7847758 and 339 1814329 - E-mail: bobrik@libero.it

### SOUTH AMERICA AND MEXICO

GEORGE PANARA

Sao Paulo - BRASIL - Tel.: +55 11 4436 9123 - Fax: +55 11 4436 12 13

### TAIWAN • MAINLAND CHINA • VIETNAM

COLMAX INTERNATIONAL LTD

2F, No.23 Lane 229 • Kuang Hwa Street • Tainan • TAIWAN

Tel. +886-6-2361683 • Fax +886-6-2361681

### UNITED KINGDOM

SELECT CYCLE COMPONENTS

Unit 3, Napoleon Business Park • Wheterby Road • DERBY • DE24 8HL

Tel. +44-0780260628 • Fax +44-1949-829039